

NOTE: PRECAST ADJUSTING RINGS, 2", 3", 4", & 6" IN HEIGHT, TO BE USED FOR GRADE ADJUSTMENT NOT LESS THAN 1'-0".

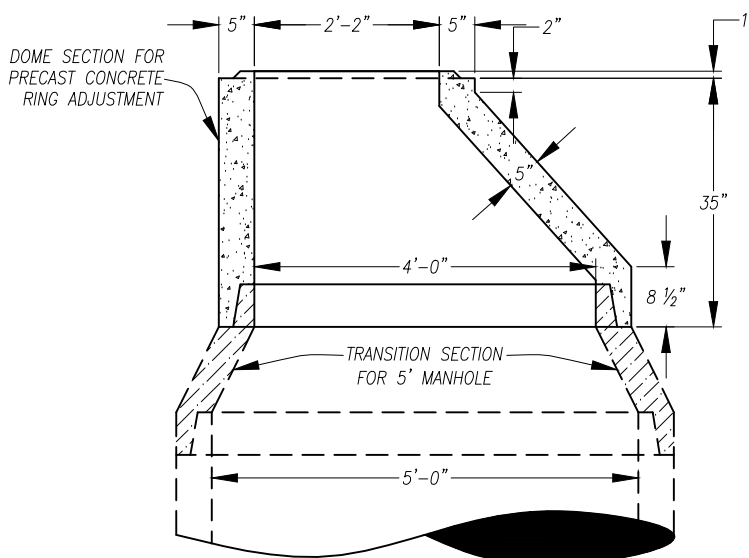
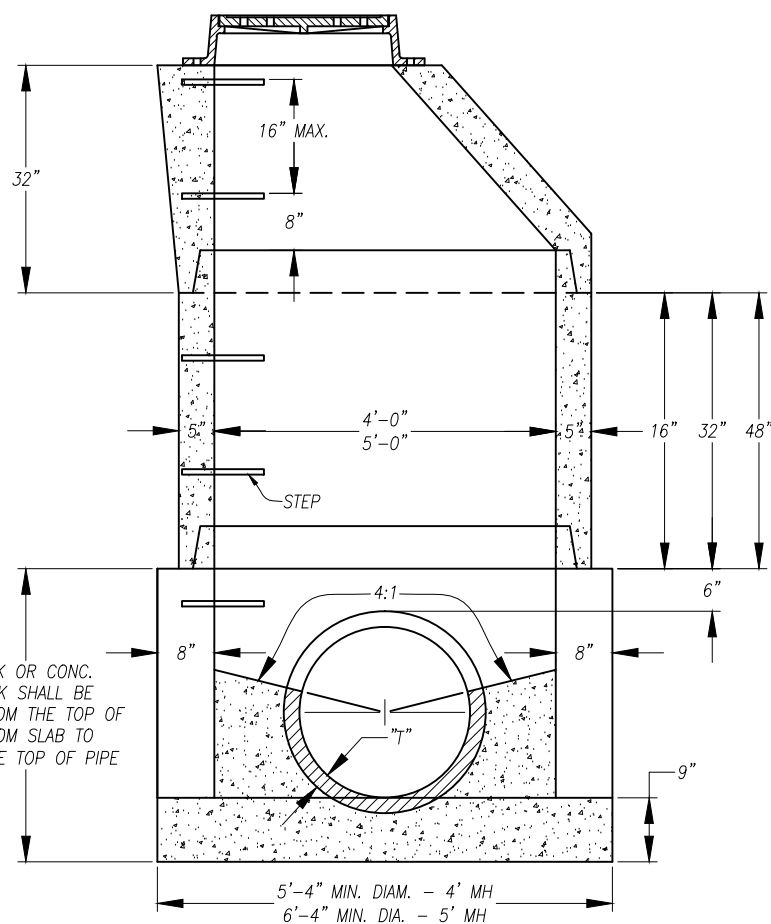

4'-0" FOR SEWERS 24" AND UNDER, STD. MANHOLE No. 3
 5'-0" FOR SEWERS 27" TO 42", STD. MANHOLE No. 4

NOTES

GENERAL: ALL JOINTS OF PIPE OPENINGS IN THE MANHOLE SHALL BE THOROUGHLY CAULKED TO PREVENT INFILTRATION. DOMES SHALL HAVE AT LEAST ONE LINE OF STEEL REINFORCEMENT WITH A MINIMUM CROSS SECTIONAL AREA OF 0.116 SQ. IN. PER LINEAL FOOT OF DOME.

MATERIALS: CONCRETE FOR THE MANHOLE BASE SHALL BE CLASS "C". PRECAST REINFORCED CONCRETE RINGS 48" IN DIAMETER SHALL MEET THE STRENGTH AND DESIGN REQUIREMENTS FOR 48" STANDARD REINFORCED CONCRETE SEWER PIPE.

ADJUSTING RINGS: PRECAST ADJUSTING RINGS SHALL BE REINFORCED WITH ONE No. 3 GAGE WIRE OR EQUIVALENT. THE TOP OF THE DOME SHALL BE PLACED AT AN ELEVATION SO THAT A MINIMUM HEIGHT OF 6" OF ADJUSTING RINGS SHALL BE USED AT ALL TIMES, UNLESS OTHERWISE SPECIFIED ON THE PLANS.

SETTING OF CASTING: THE BASE OF THE FRAME SHALL BE SET IN A FULL BED OF PORTLAND CEMENT MORTAR AND SO ADJUSTED TO CONFORM TO THE FINISHED GROUND OR PAVEMENT GRADE.

CASTINGS AND STEPS: MANHOLE CASTINGS SHALL BE NEENAH R-1668 FRAME & LID, EAST JORDAN 1045 OR ALLEN COUNTY ENGINEER APPROVED EQUAL. STEPS SHALL BE NEENAH R-1980-C OR ALLEN COUNTY ENGINEER APPROVED EQUAL. CASTINGS AND STEPS SHALL HAVE ONE COAT OF ASPHALT PAINT.

MANHOLES USED AS CATCH BASINS: SEE CASTINGS SPECIFIED ON STD. DRWG. CB-1.

NOTE: MANHOLE DETAILS FOR SEWERS OVER 42" WILL BE SHOWN ON THE CONSTRUCTION PLANS.

REVISIONS			ALLEN COUNTY, OHIO
NO.	DATE	BY	COUNTY ENGINEER
1	6-3-76	TJP	MANHOLE DETAILS - PRECAST CONCRETE, TONGUE & GROOVED, REINFORCED
2	11-14-89	TJP	
3	10-5-06	RJM	
4	1-16-13	RJM	
5	5-16-16	ZJG	
			STANDARD CONSTRUCTION DRAWING MH-3 & 4
			DRAWN BY: Z.J.G. APPROVED BY: B. E. RHODES